

QC2600

STABILIZER HULL UNIT

DESCRIPTION:

A stabilizer hull unit is the energy transfer device in Quantum’s fin stabilizer systems. The hull unit is installed in the turn of the bilge with its main shaft penetrating through the vessel’s hull to connect to the stabilizer fin. It uses hydraulic cylinders to rotate the main shaft, which in turn, deflects the fin to reduce roll.

Designed using the latest technology and high-quality materials, the QC2600 is a rugged machine that is capable of significantly reducing vessel roll during both underway and Zero Speed™ operations. The QC2600 can be made available with built-in porting and electronics to allow this unit to be used with Quantum’s innovative extendable (XT™) fin system, or as a Heavy Duty (HD) unit with larger load bearing components.

FEATURES:

- **SIMPLE INSTALLATION:** The hull unit is delivered fully assembled for easy installation into the vessel’s structure, via the supplied welding bushing.
- **PRECISE FITS AND CLEARANCES:** The main shaft features a tapered cut for true stabilizer fin connection, and a rotating-spline connection to the tiller and hydraulic cylinders. These precise fits promote a smooth transfer of energy from the hydraulic cylinders to the stabilizer fin.
- **SAFETY PRECAUTIONS:** Hydraulic centering cylinders are used to return the fin to its center position in the event of an emergency.
- **LOAD HANDLING:** A series of sleeve bearings and a spherical roller bearing distribute the motions and loads imposed on the hull unit.
- **MINIMAL MAINTENANCE:** The hull unit is simple to maintain during normal operation, with stainless steel components used extensively to minimize corrosion. Easily accessible grease nipples are built-in with internal porting for regular greasing of the bearings. The unit is designed for replacement of o-rings, seals, and bearings during vessel haul-outs every other year.

*Equipment is covered by Quantum’s 1 year comprehensive warranty.
Service and technical support are available worldwide.*

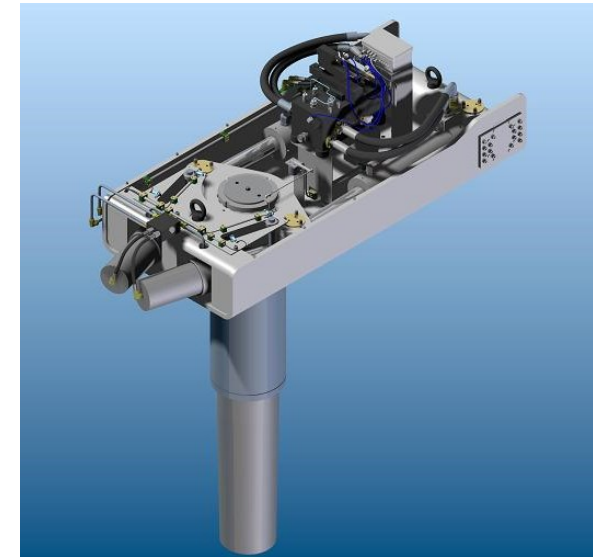

Typical Vessel Length*	60-90m (200-300ft)
Fin Size Range**	7.0-9.0m ² (75-97ft ²)
XT™ Fin Size(s) Available**	8.8x11.1m ² (95x120ft ²)
Length (including centering cylinders)***	2230mm (88")
Width***	960mm (38")
Height (overall)***	2500mm (98")
Height (inside vessel after installation)***	1600mm (63")
Weight (dry)***	2570kg (5700 lbs)

**Provided for reference only. Consult a Quantum representative for system sizing.*

*** Size may be limited for higher speed vessels; see a Quantum representative for more information.*

**** Dimensions are approximate dimensions of the equipment, and do not include service allowances.*

All information contained within this document remains the absolute property of the Quantum Group and is subject to change at any time. Any use of the information for other than the intended purpose is expressly forbidden. Consult a Quantum representative for more information.

INNOVATION

