

e1500 Hull Unit Features & Specs

DESCRIPTION

Quantum’s e-FIN Hull Unit (e1500), is the latest cutting-edge solution for electric stabilizers offering unparalleled energy efficiency, responsiveness, and durability. The e-FIN servo motor receives the appropriate voltage and current from the EPU, to produce precise motion. This motion is converted in the compact housing with a unique, Quantum designed reduction gearbox, to seamlessly rotate the fin to the optimal velocity and angle. The fast responsiveness of the electric system provides instantaneous stabilization where it is needed. The rugged lower bearing housing with double roller bearings ensures minimal maintenance. In addition, a hand operated locking mechanism is easily accessible to center the fins, should an unexpected power failure occur.

FEATURES:

- Low power profile
- Lowest dB noise generation in class
- Designed for standard and XT™ fin systems
- AC and DC Volt options
- Passive air cooling, eliminating cooling water failure points
- Easy access and minimal maintenance

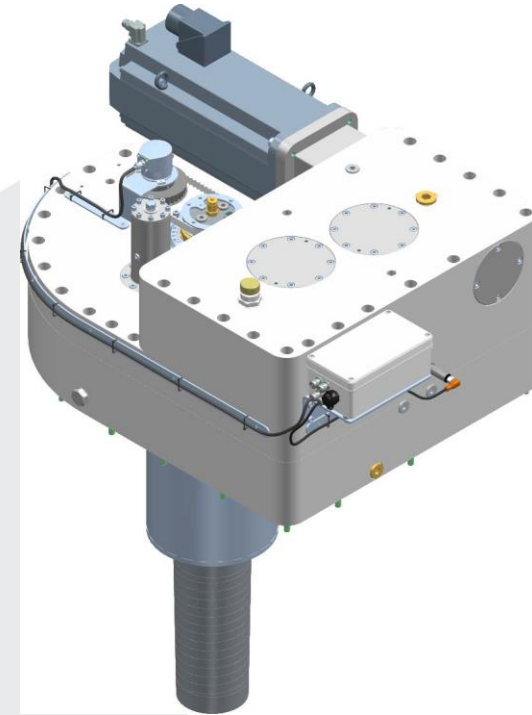

Description	Symbol	Unit	Value
Ambient temperature range for operation with nominal data	T _{AMB_NOM}	°C	-5 ... +45
Cooling type			Passive air cooling
Protection category IP to EN 60529			IP 54
Mass	m	kg	839
Mechanical operating range	°	deg	-55 to +55
Dimensions	HxDxW	mm	1310x729x972

Equipment is covered by Quantum’s 1-year comprehensive warranty. Service and technical support are available worldwide.